



Environmental Engineering

# Company Profile

- Decontamination and restoration of waterways
- Treatment and dewatering of industrial sludge
- Removal of silt, sludge, sand and trash
- Treatment and separation of all materials
- Ready for recycling of materials

**ALL IN ONE SYSTEM!**







# Your Partner for Environmental Engineering

Uwt.swiss develops and produces sludge treatment systems for the restoration of waterways and for industrial sludge treatment. We offer ,best in class' separation, sludge treatment and dewatering machines in one fully integrated system, managed by our propriety Automated Intelligence Control System AICS.



- During the last 100 years many waterways have been filled up by mud and sludge caused by industrialization, civilization and natural process
- Unfiltered wastewater from factories, the mining industry and households have been dumped into waterways over the years.
- Waterways have become highly contaminated and poisoned
- The economical and ecological damages run into the billions every year (flooding damage, water contamination)
- Traditional methods of extraction are expensive with no opportunity for recycling
- Sludge and trash in the waterways contain valuable substances, which can be recycled

**Our system is the only solution worldwide**





- Restoration of waterways
- Decontamination of waterways
- Restoration of dams and reservoirs
- Treatment and processing of drilling sludge
- Extrusion and tunnel construction
- Processing of gravel and sand
- Soil washing plants
- Mining plants



# Our successful SRD 130

Polymer-Station and Control Center -  
delivered in a 3.5 tonne easily transported  
trailer



The Mobile Unit Desludging System built on a 40' Container platform,  
transportable with standard container trucks

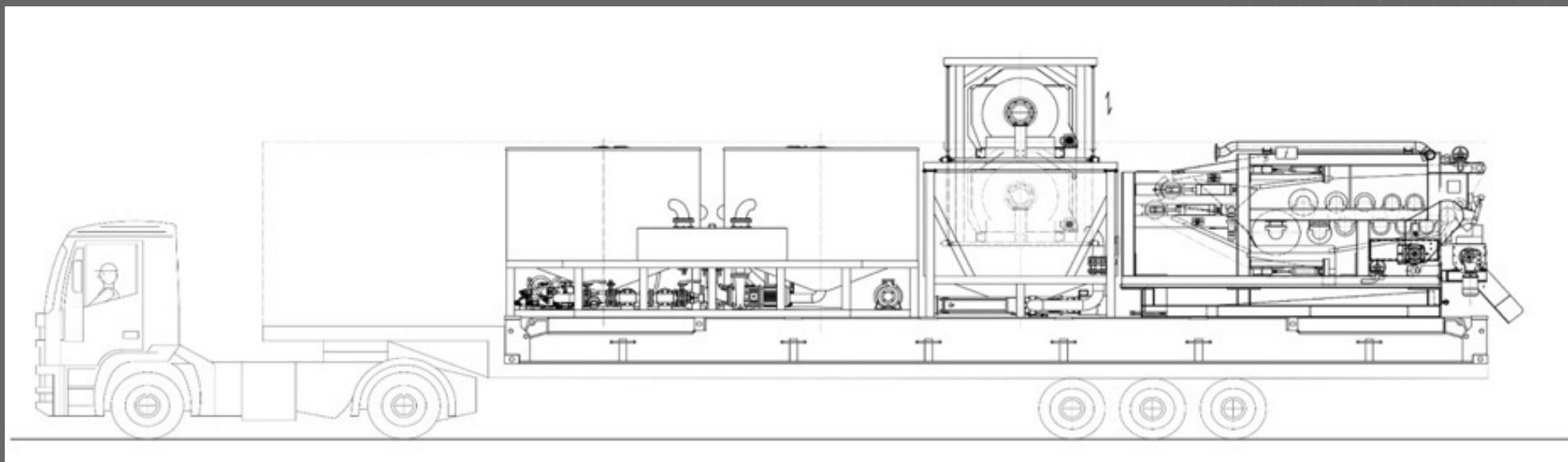

# Evolution - SRD 130 to SRD 150

SRD 130



SRD 150



**Control & Polymer Unit**  
- higher capacity  
- intelligent control



**Sludge Treatment Unit**  
- better sedimentation  
- optimal polymer dosage



**Separation Unit**  
- much higher capacity  
- dry output



**Dewatering Unit**  
- faster  
- higher capacity

- The SRD 150 system
  - separates sand, which can be sold to the construction industry
  - separates trash, which can be recycled or properly disposed of
  - separates organic and mineralic material, which can be reused in the agricultural and construction industries
  - conditions and dewateres the sludge to a highly dry substance grade - these sludge filter cakes can be reused in many different ways
- The SRD 150 system converts the filtrate water into clear water
  - The clear water can be safely discharged back to the waterways or can be further processed by additional water treatment systems (for instance drinking water treatment plants)



## SRD 150 capabilities



# SRD 150 – The Business Case

- The SRD 150 - a compact mobile system consisting of a Separation Unit, a Sludge Treatment Unit, a Dewatering Unit and a Polymer and Process Water Unit
- Easily installed, with a reduced footprint, due to the compact design
- Easily expandable – for instance the output capacity of the dry sludge can be doubled by just adding a sludge treatment unit and a dewatering unit to the standard SRD150 configuration
- The Automated Intelligence Control System (AICS) - proprietary software that uses dozens of sensors to efficiently manage the whole process across the 4 units
- greater efficiencies and reduced environmental risks
- Lower Capital costs compared to purchasing each machine separately from other vendors
- A Return on Investment (ROI) within one year
- Lower Operational costs:
  - just one operator can manage the whole system,
  - less polymer required
  - Less electricity consumption

# SRD 150 - New Version in 2021

- The SRD 150 System consists of 4 fully integrated units, installed in in 20' containers.
- **The Separation Unit** separates coarse material, sand and water/sludge suspension. Coarse material and sand are dewatered and discharged separately.
- The water/sludge suspension is then pumped into the **Sludge Treatment Unit**, where the sludge is sedimented and thickened by adding a polymer solution, discharging clear water.
- The sedimented and thickened sludge is pumped to the **Dewatering Unit**, where the sludge is dewatered up to 75% dryness. The filtrate water is pumped back to the Separation Unit and is processed through the whole system again in order to discharge only clear water .
- **The Polymer and Control Unit** consists of a polymer station, process water station and the Automated Intelligence Control System (AICS). This Control System manages the overall processes in a fully automated way.

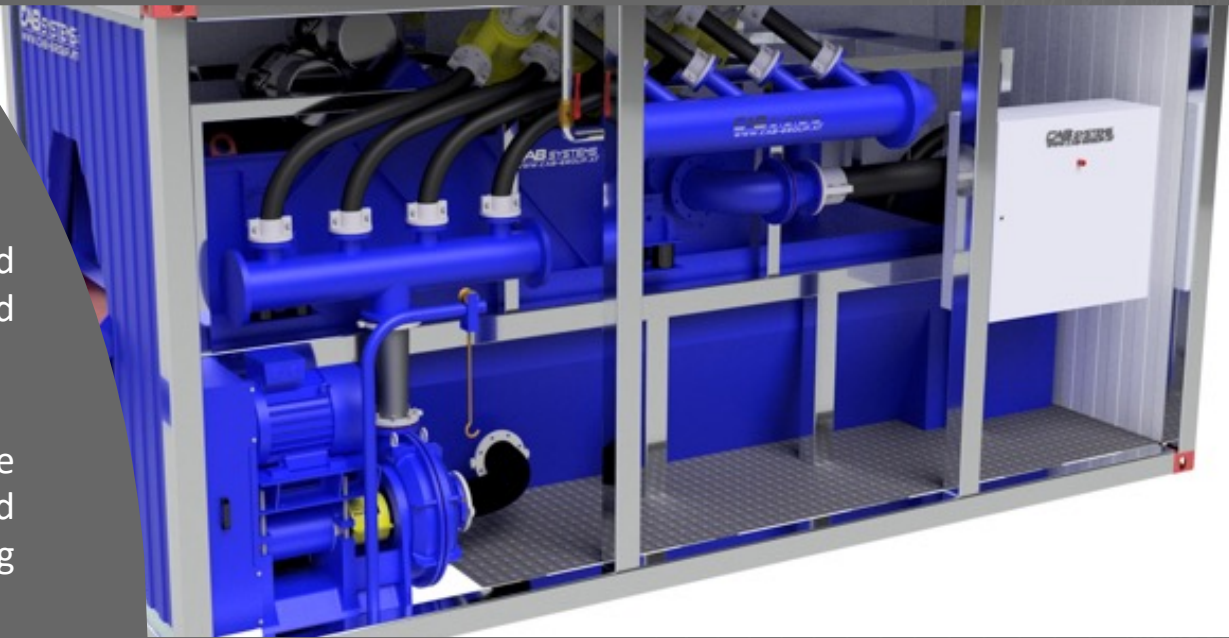



# SRD 150: Flexible Installation

## Installation A



Separation - Unit



Control & Polymer Unit



Sludge Treatment - Unit



Dewatering - Unit

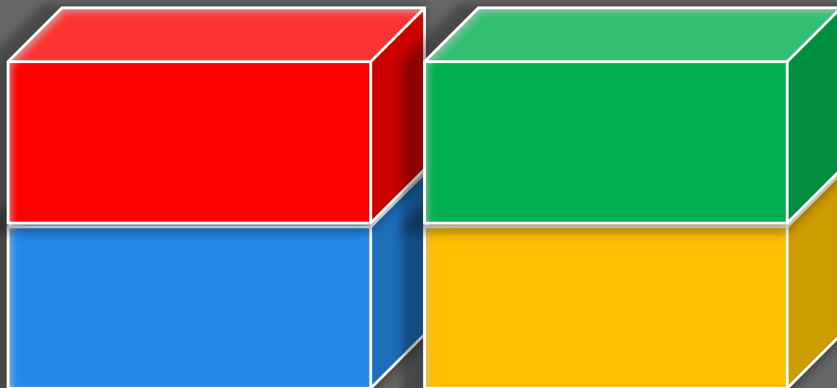

Installation B

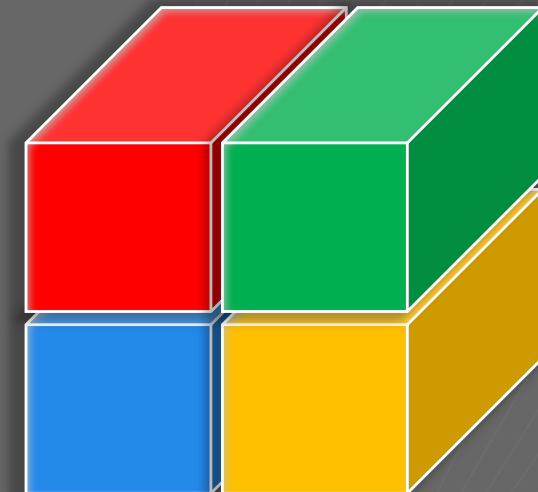

Installation C

# SRD 150: process scheme

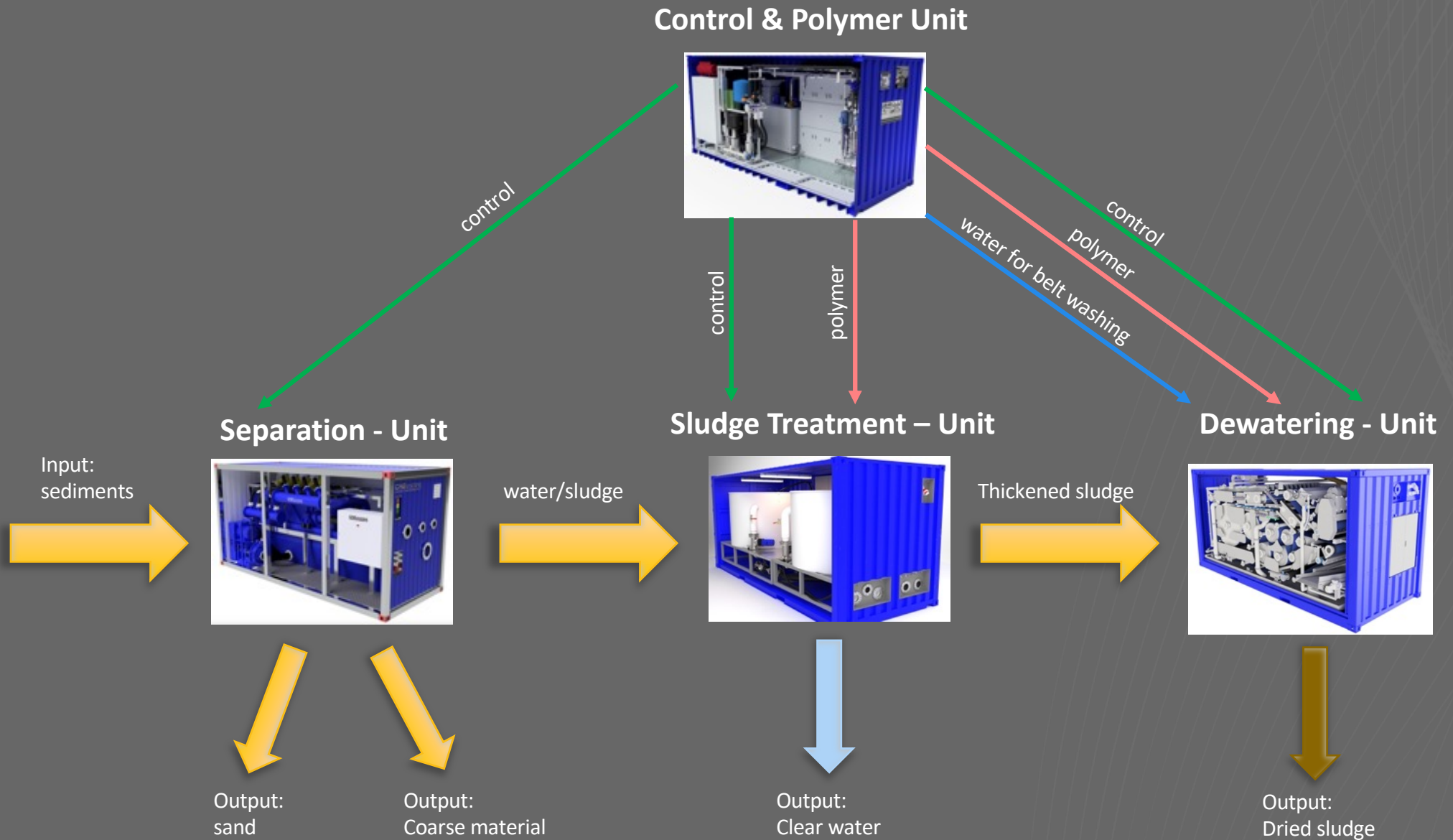

<i>Specifications</i>	<i>Description</i>
Mobility	Best mobility, all units in 20' Containers
Total installation footprint	Approx.. 100m <sup>2</sup> (containers are stackable)
Capacity (discharge)	Sand: 20t/h Sludge filter cakes: 10t/h Coarse material: 10t/h
Safety	All units are built in 20' lockable containers
Maintenance	Easy to maintain, low maintenance costs
Control system	Automated Intelligence Control System (AICS)
Polymer station	Fully integrated and automated polymer system
Abrasion	Very low rate of abrasion
Process water	Consumption is only 6-15m <sup>3</sup> /h (depending on configuration)
Smart Sensors	Over 60 sensors in the whole system



- Our SRD 150-system combines 4 machines in one compact and mobile system!
  - Separation unit
  - Sludge Treatment unit
  - Dewatering unit
  - Polymer & Process Water unit
- The purchase costs of our SRD 150 is much lower, than the purchase costs of each machine separately from other vendors.
- The investment is paid back within one year of operations due to very low operational costs
- Compared to other dewatering systems the SRD 150 dewatering unit needs just 8 kW per hour. For example, the power consumption of a centrifugal extractor is over 100 kW per hour and the purchase costs and the maintenance costs of a centrifugal extractor is many time higher than our dewatering unit (SRD 150).
- The SRD 150 needs just one person to operate the whole system and consumes less electricity and polymer. The SRD 150 operating costs are much lower than with other third party machines.
- The SRD 150 output capacity is easy to expand - e.g. adding a thickener unit and a dewatering unit to the standard configuration doubles the output capacity.

- All 4 units are connected in the fully integrated SRD 150, and are centrally managed by our AICS software control system, greatly increasing efficiency
- Greatly reduced environmental with dozens of sensors to monitor all events
- Easy to install, with a smaller footprint, due to standardized 20' container system
- The SRD 150 system separates sand, which can be sold to construction industry
- The SRD 150 system separates trash, which can also recycled or properly disposed
- The SRD 150 system separates organics and minerals, which can be reused in the agriculture and construction industries
- The SRD 150 system conditions and dewateres the sludge to a high dry substance grade. Therefore the disposal costs are reduced by over 50% or the sludge cakes can be reused in many different ways.
- Our SRD 150 system changes the filtrate water into clear water. The clear water can be safely discharged back to the waterways or can be further processed by additional water treatment systems, like drinking water treatment plants

# SRD 150 – Separation Unit





# SRD 150 – Separation Unit

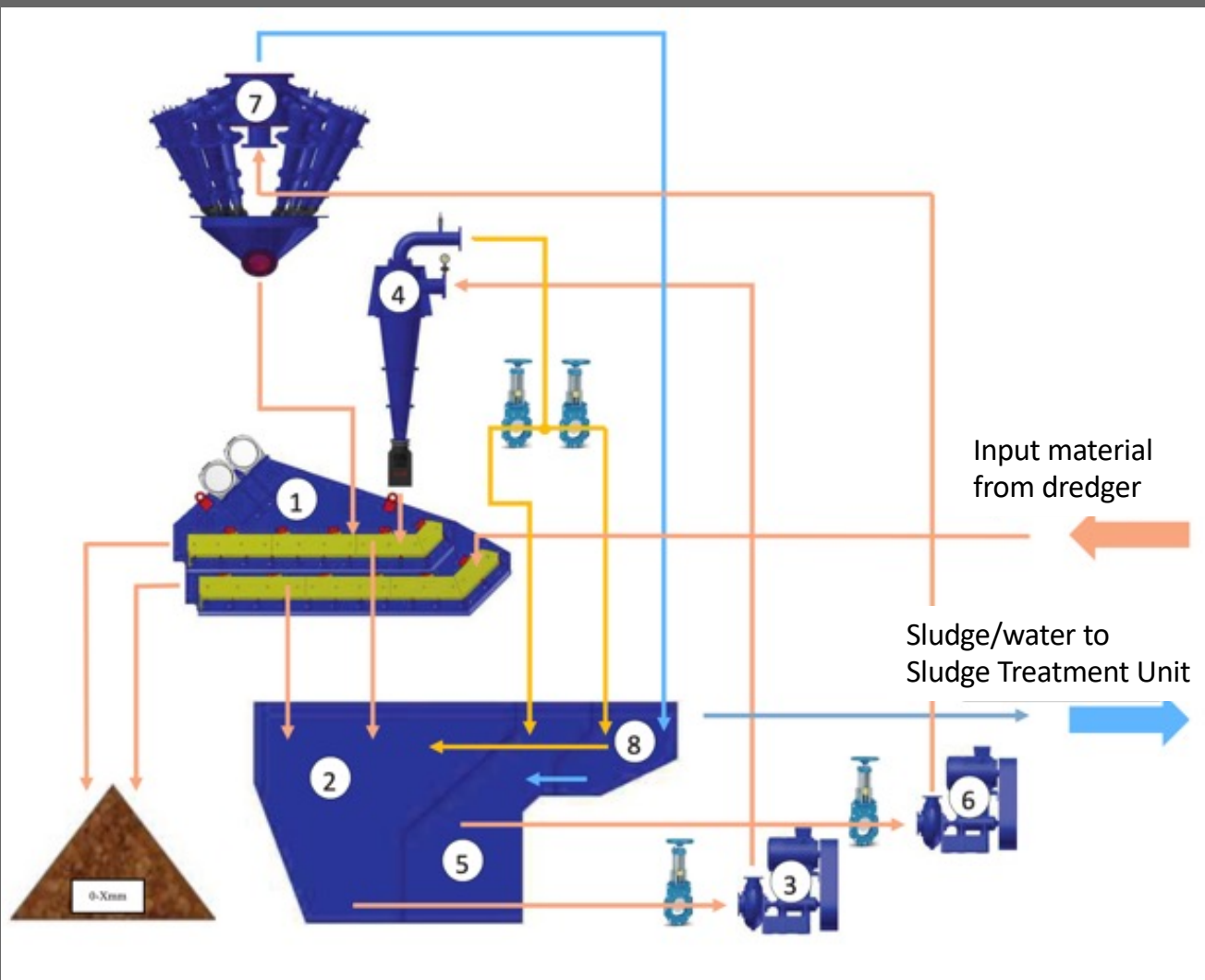

The input material, pumped by dredger, will go through the 1st vibrating screen, lower deck **1** > separates coarse material.

The rest material (sludge/water/sand) will go into the tank **2** and is pumped **3** into first hydro-cyclone **4**.

The output material (coarse sand) will go into the 2nd vibrating screen, upper deck **1**. The overflow will go into tank **5** and is pumped **6** into the second hydro-cyclone **7**.

The output material (fine sand) will also sent to the 2nd vibrating screen, upper deck **1**. The overflow of sludge/water will go into tank **8** and with two pumps into the Sludge Treatment Unit.



# SRD 150 – Sludge Treatment Unit



# SRD 150 – Sludge Treatment Unit

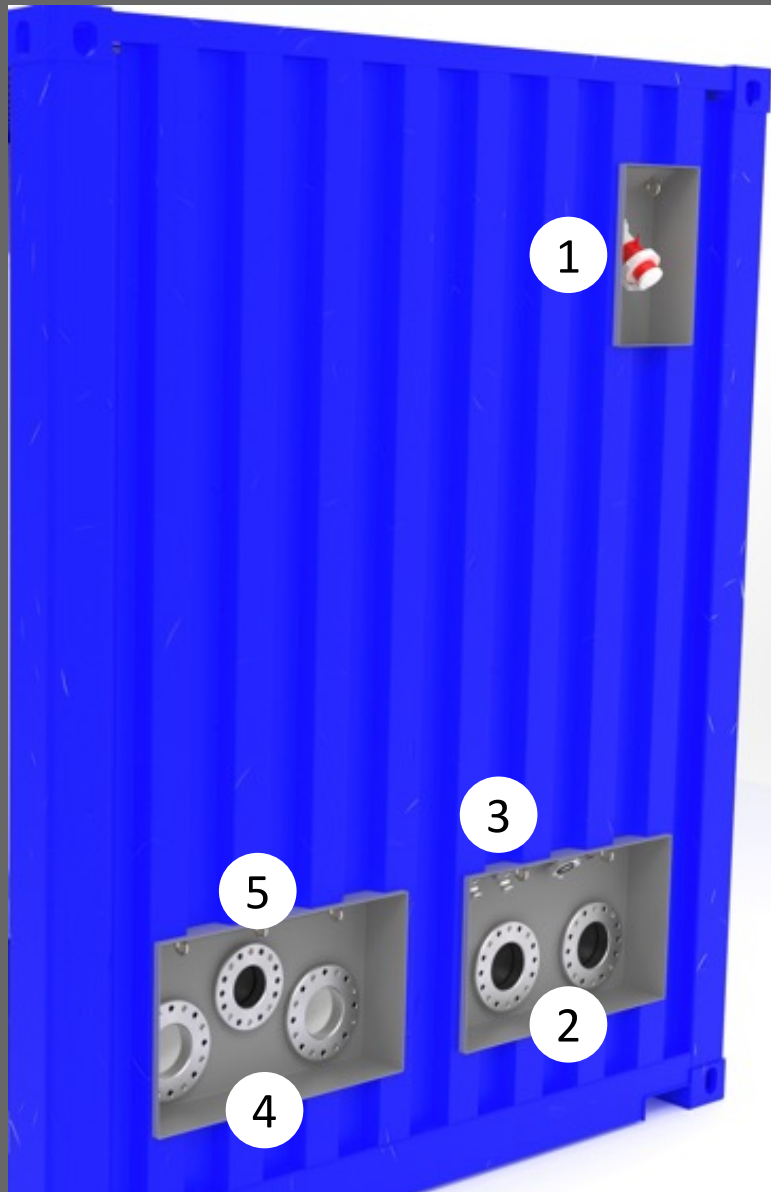

Adapter for power supply for the Sludge Treatment Unit incl. communication cable adapter ①

Two input adapters ② for the water/sludge mixtures. Each input leads to one thickener

Two polymer input adapters ③, each adapter for one thickener

Two clear water outlet adapters ④. One pumps the clear water to the waterways. The other pumps the clear water back to the Separation Unit when circulation mode is active and in case further processing of sludge is required.

Outlet of sedimented sludge ⑤ from the thickener process to be then pumped to the Dewatering Unit



# SRD 150 – Sludge Treatment Unit

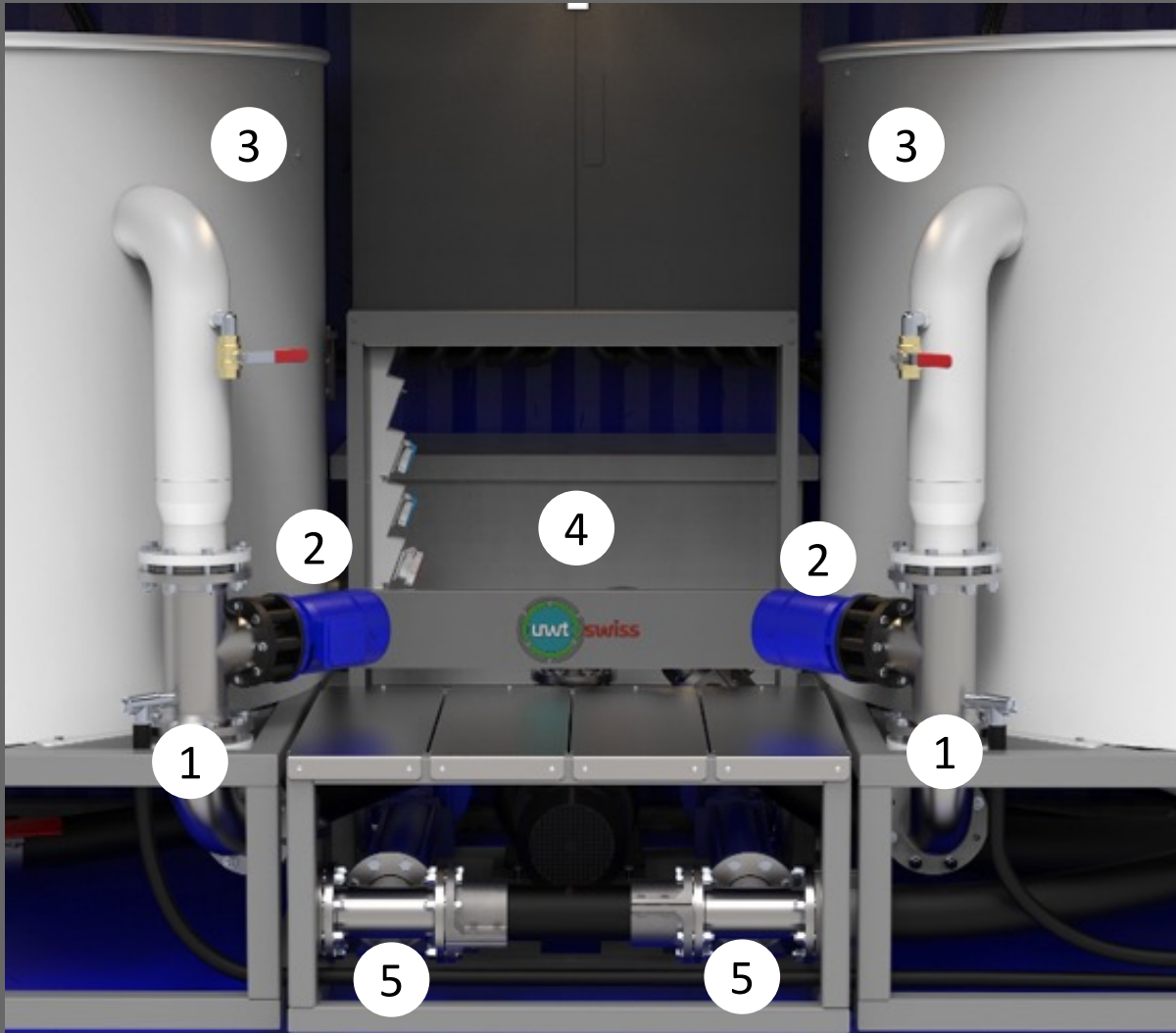

The water/sludge mixture is pumped through these two pipes ① to the two thickeners.

Polymere inline mixtures ② are introduced within these pipes, mixing the polymer into the water/sludge before entering the thickeners ③.

In the two thickeners ③ the sludge is sedimented and separated from the clear water.

The clear water from the overflow of the thickeners enters the clearwatertank ④. From this clearwatertank the water is pumped either to the waterways or back to the Separation Unit in case of circulation mode

The sedimented sludge is pumped by the two sledge-pumps ⑤ from the bottom of the thickeners to the Dewatering Unit

# SRD 150 – Sludge Treatment Unit

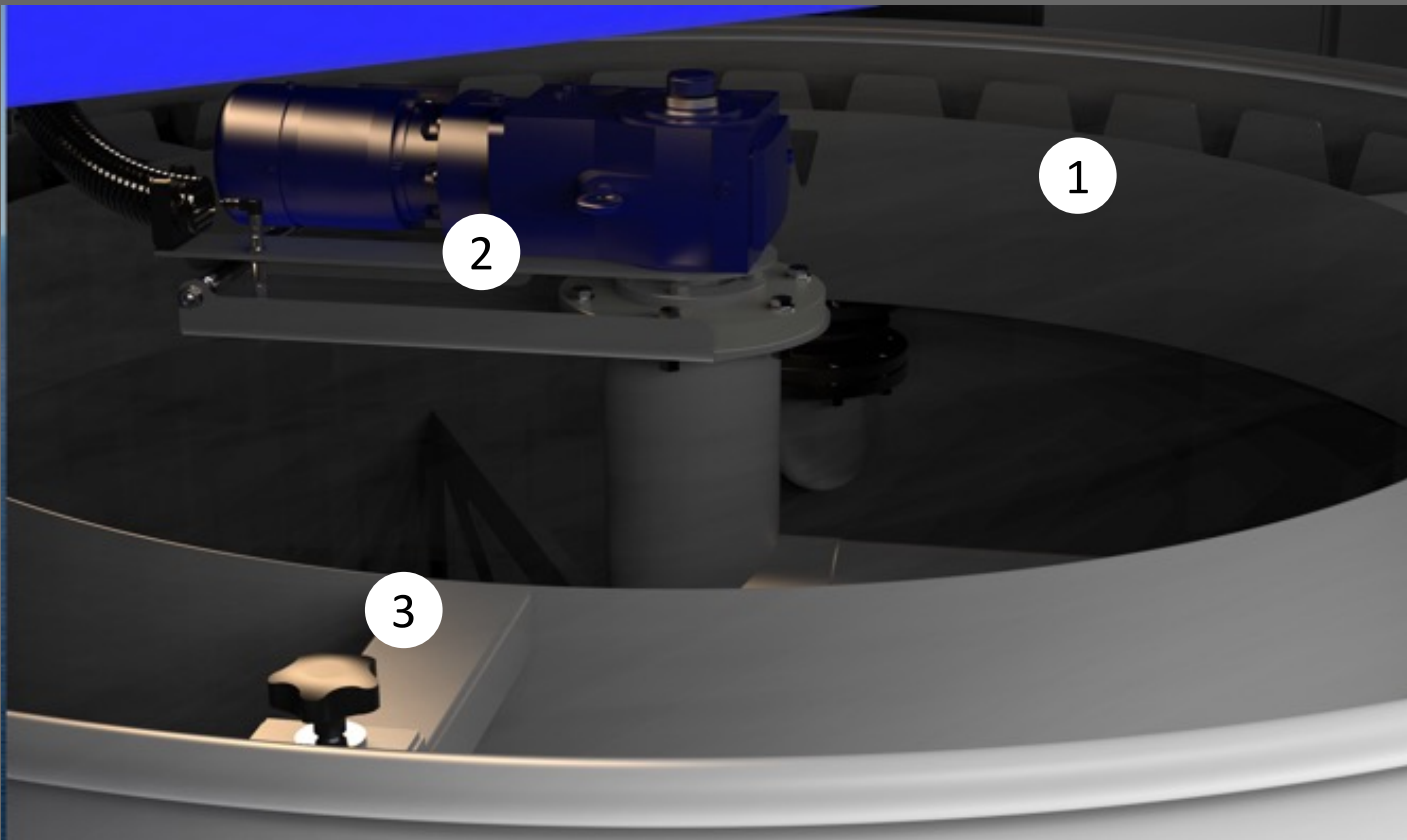

In the thickeners there are the overflow-systems ①. Clear water will be collected and then flow to the clearwatertank.

The sludge scrapers ② slowly move the sedimented sludge to the bottom outlet of the thickeners.

The overflow system can be horizontally adjusted by the overflow-adjustment ③.

# SRD 150 – Dewatering Unit





## 1. Predewatering Section with Chicanes

## 2. Wedge Shaped Section

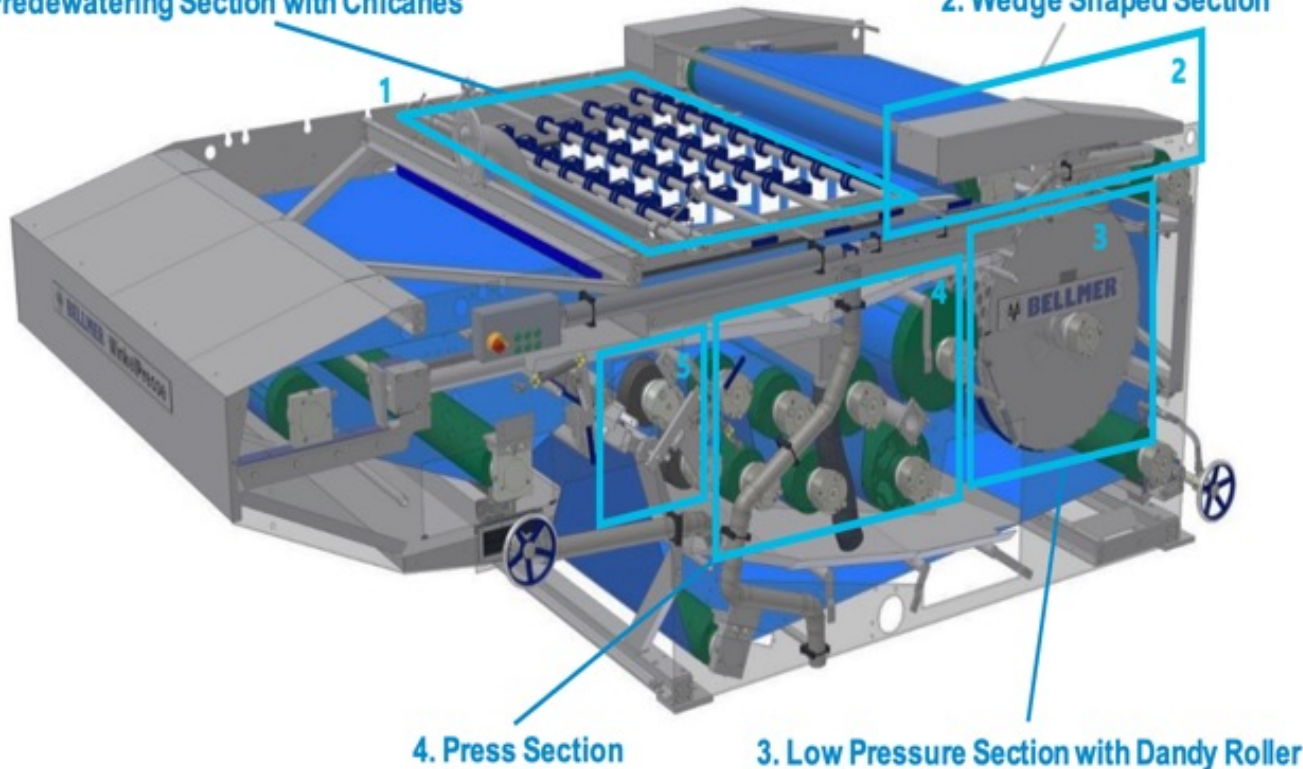

## 4. Press Section

## 3. Low Pressure Section with Dandy Roller

**1. Predewatering Section with Chicanes:**  
After leaving the feed nozzle the conditioned sludge flows to the rotating upper belt. Sludge is dammed up by the so-called calibrating plate, which evenly spreads it over the entire belt width. The chicanes constantly agitate the suspension on the horizontal belt area so that no liquid remains on the surface of the layer of solids. At the same time enclosed water is freed. The wedge shaped chicanes plough furrows in the sludge cake as it forms. This exposes the gravity dewatering belt section so that remaining water can flow off through the belt.

**2. Wedge Shaped Section:**  
After the pre dewatering section the sludge becomes packed between the two rotating belts and conveyed to the wedge-shaped section. The dewatering is effected by increasing pressure.

## 3. Low Pressure with Dandy Roller:

With the extreme large diameter of the dandy roller a slow pressure increase is guaranteed. The shovel design inside the dandy roller allows effective water removal to both sides and prevents rewetting of the sludge. Furthermore, the large diameter assures a high capacity.

## 4. Press Section:

The sludge cake is further dewatered in s-shaped wraps between the belts by the increasing pressure of the press rollers. The additionally occurring kneading and shearing effect frees enclosed liquid which results in an even higher final dry solids content. The different roller diameters allow a smooth pressure build-up for a gradual dewatering process to achieve best possible results.

# SRD 150 – Polymer & Control Unit



# SRD 150 – Polymer & Control Unit

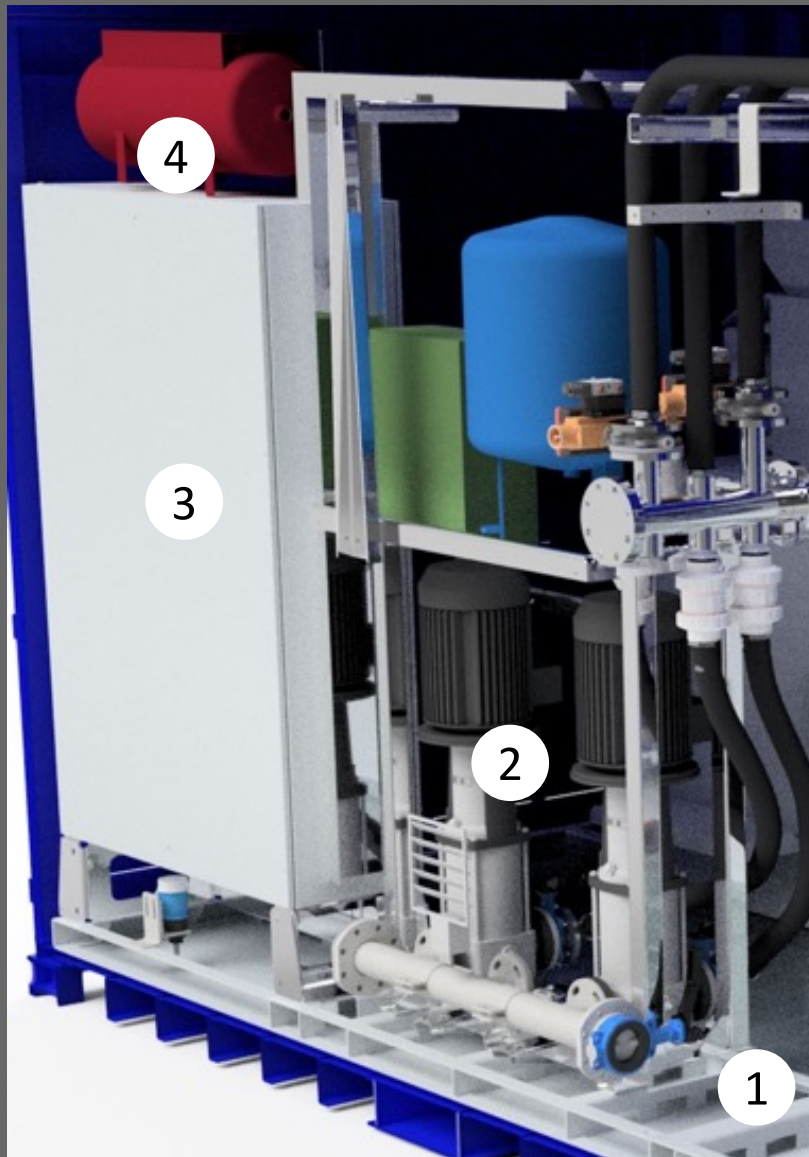

The process water tank **1**, not visible in this picture, contains the process water which is used to clean the belt filters, to prepare the polymer solution and for subsequent diluting of the polymer solution (adding more water to the polymer solution). The process water is pumped from the waterways and cleaned by an automatic backwash filter before being filled in the process water tank. Optionally, the process water to prepare the polymer solution can also be taken from a water hydrant.

Two redundant booster pumps **2**, which boost the pressure up to 7 bar for cleaning system of the beltfilterpress and extend the pressure for the backwashing of the process water filter.

Switch cabinet including control system **3** for all units including frequency converters and SPS for all components of the Polymer & Control Unit.

Compressor **4** for serving pressurized air to sleeve valves.



# SRD 150 – Polymer & Control Unit

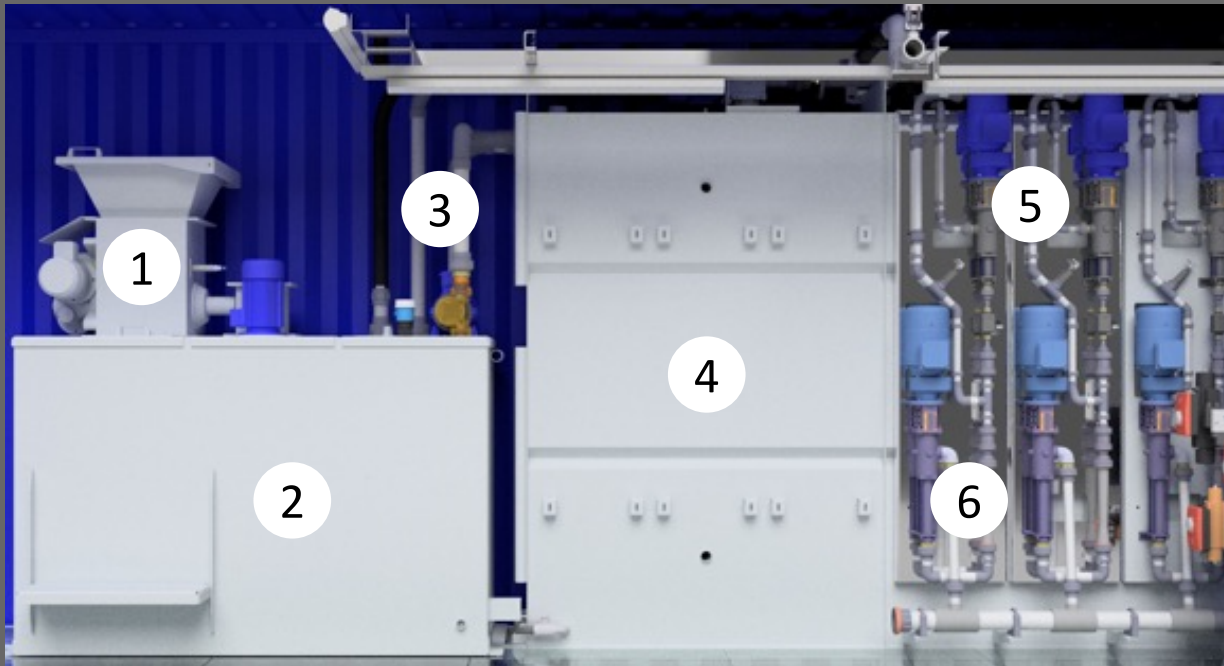

Dosing device for polymer powder **1**. After first time calibration (e.g. 0.5% solution) the appropriate dosage will be filled in the reaction tank and be mixed with water .

In the reaction tank **2** the agitator is mixing the polymer powder with water in order to get an optimal polymer solution. The reaction time can be manually entered or automatically adjusted by the control system based on polymer consumption.

The transfer pump **3** delivers the polymer solution to the storage tank **4**. The agitator (mixer) keeps the polymer in solution in order not to clump.

The three polymer dosing pumps **5** suck in the polymer solution from the storage tank. The polymer solution is pumped through the subsequent dilution devices to the sludge treatment unit (two thickeners) and the dewatering unit. The dosage is automatically adjusted by the control system based on volume and dry substance of the incoming water/sludge suspension.

The three subsequent dilution pumps **6** mix additional water to the polymer solution in order to improve the polymer and sludge reaction. The volume of this additional water can be adjusted .



# Application: Restoration Waterways

## Waterways

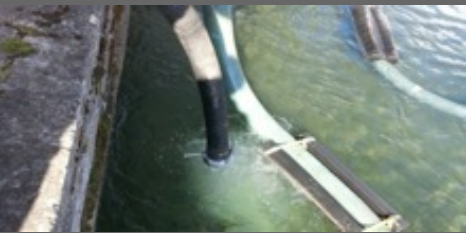

The clean water will be pumped back to the water way

## Logistics



The sludge treatment system SRD 150 reduces the volume of the dried sludge massively with a dry substance of up to 75%.

## Sludge Dredging



The amphibious vehicle pumps a mixture of water and sludge from the waterway with a max. pumping capacity of 150 m<sup>3</sup>/h into the sludge treatment system.

## Sludge Tubes



the sludge/water suspension can be transported in tubes over a distance of up to 1'000 meters to the sludge treatment system and expandable with booster pump

## Mobile Sludge Treatment System SRD 150



Dewatering - Unit



Separation - Unit

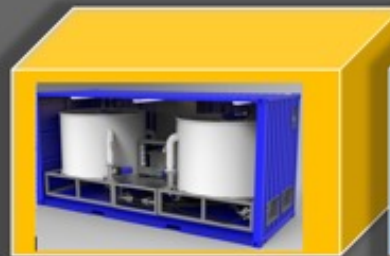

Sludge Treatment - Unit



Control & Polymer Unit

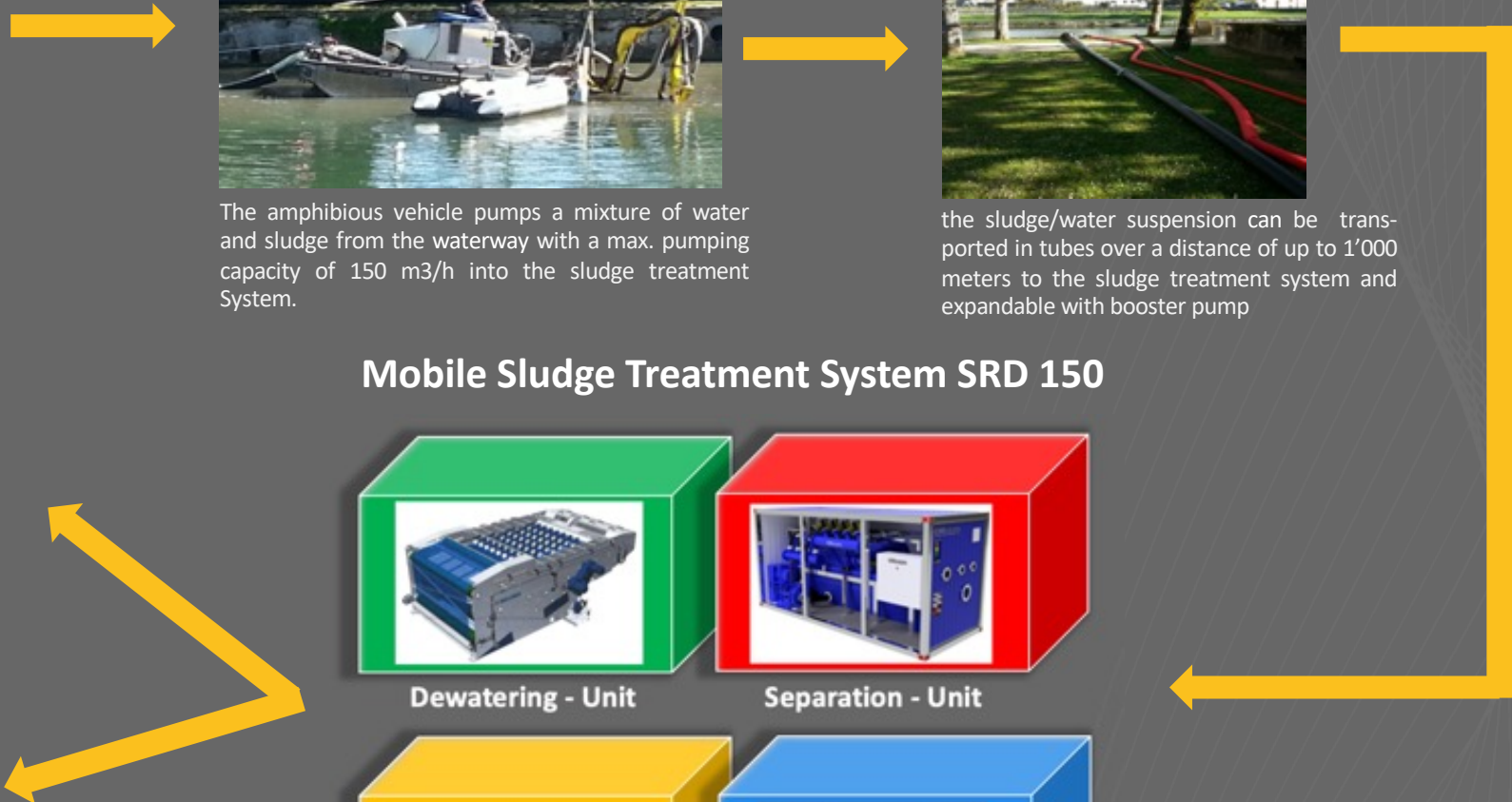



# Application: Industrial Sludge

- The SRD 150 systems can also be used to treat, process and dewater any kind of industrial sludge (e.g. tunnel construction, drilling, mining, soil washing or other plants producing industrial sludge).
- These pictures show our system being used at a sugar beets factory. The water used to wash the sugar beets was treated and the sludge was dewatered.



# Selection of References

- Giengen an der Brenz „Altarm“ (Germany)
  - Year 2014
  - River and small lake with contaminated sludge
  - Customer: Regierungspräsidium Stuttgart, Germany
- Laupheim „Achterweiher“ (Germany)
  - Year 2014
  - Lake with normal sludge
  - Customer: Stadt Laupheim, City in Germany
- Laupheim Schlossweiher (Germany)
  - Year 2015
  - Lake with normal sludge
  - Customer: Stadt Laupheim, City in Germany
- L'isle Kanton Waadt Venoge (Switzerland)
  - Year 2015/16
  - Lake with normal sludge
  - Customer: Direction Générale de l'Environnement du canton Vaud

# Selection of References

- Yachthafen Waltrop (Germany)
  - Year 2017
  - Port in Germany
  - Customer: Erbgemeinschaft Yachthafen Waltrop
- Rivers and Canals in Shenzhen (China)
  - Year 2018/2019
  - Rivers and canals with highly contaminated sludge
  - Customer: Powerchina Water Environment Governance, Shenzhen, China
- Anklam (Germany)
  - Year 2018
  - Treatment and Processing of sludge from washing plant of Sugar beets
  - Customer: Sugar beet factory in Anklam (Germany), Suiker Unie GmbH & KG Anklam, Germany
- Lake in Regensburg (Germany)
  - Year 2019/2020
  - Lake with normal sludge
  - Customer: Wasserstrassen- und Schifffahrtsverwaltung Regensburg



# Selection of References

- Grünberger Kieswerk (Austria)
  - Year 2021
  - Gravel Plant
  - Customer: Grünberger Kieswerk (Austria)
- Salzburger Sand Kieswerke
  - Year 2022
  - Gravel Plant
  - Customer: SSK, Salzburger Sandkieswerke
- Bangkok (Thailand)
  - Year 2022
  - Cleaning and desludging canals of Bangkok
  - Customer: UCI Bangkok Thailand
- Bangkok (Thailand)
  - Year 2022
  - Cleaning and desludging canals of Bangkok
  - Customer: Bangkok Metropolitan Administration, Thailand



# Contact Information

CK Aqua AG  
Margritenweg 5  
6390 Engelberg  
Switzerland  
website: [www.uwt.swiss](http://www.uwt.swiss)



Christian Knuchel  
eMail: [ck@uwt.swiss](mailto:ck@uwt.swiss)  
Phone: +41 79 831 08 12

Bruno Felskowsky  
eMail: [bf@uwt.swiss](mailto:bf@uwt.swiss)  
Tel: +41 44 811 26 14